



BODYMED[®]

ZZAEV820OTC

PAIN RELIEF SYSTEM



BodyMed
Hudson, Ohio 44236
1.866.528.2152



INDEX

Chapter Contents	Page
Index	1
1. Pain Relief System	2
2. Important Safety Instructions	2
3. Package Contents	5
4. Parts Of Stimulator	6
5. How Your TENS Works.	7
6. Conditions That May Affect Your Pain Relief System	7
7. Quick Operation Guide	7
8. Attachment Of Electrode Lead Wires	8
9. Lead Wire Maintenance	8
10. Electrode Options	9
11. Electrode Placement	9
12. Tips For Skin Care	9
13. Application Of Re-Usable Self Adhesive Electrodes.....	10
14. Operating Instructions	12
15. Battery Information	14
16. Maintenance, Transportation And Storage Of TENS Device.....	16
17. Safety-Technical Controls	16
18. When To Order New Electrodes	17
19. Warranty	17
20. Replacement Parts	17
21. Conformity To Standards.....	17
22. Trouble shooting Guide	18
23. Stimulator Technical Specifications	19

Chapter 1: PAIN RELIEF SYSTEM

Intended Use

The ZZA8EV8200TC Pain Relief System is intended for temporary relief of pain associated with sore and aching muscles in the lower back due to strain from exercise or normal household and work activities.

About TENS Technology

Transcutaneous Electrical Nerve Stimulation is an approved non-invasive drug-free method of lower back pain management. It relieves pain by sending small electrical impulses through electrodes placed on the skin to underlying fibers. TENS is believed to work by two different mechanisms. First, electrical stimulation of the nerve fibers can block a pain signal from being carried to the brain. If the signal is blocked, pain is not perceived. Secondly, the body has its own mechanism for suppressing pain. It does this by releasing natural chemicals called endorphins in the brain which act as analgesics. TENS may activate this mechanism. By effectively managing pain without drugs, TENS allows many people with lower back pain conditions to resume daily activity.

Chapter 2: IMPORTANT SAFETY INFORMATION

Read instruction manual before operation. Be sure to comply with all “**CAUTIONS**” and “**WARNINGS**” in the manual. Failure to follow instructions can cause harm to user or device.

CAUTION: Indicates matters in which bodily harm or material damage can occur.

WARNING: Indicates what you cannot do with device.

Please read the following information carefully before using this Low Back Pain Relief System.



WARNING: DO NOT USE THIS SYSTEM IF ANY OF THE FOLLOWING CONDITIONS ARE PRESENT.

2

- Do not use this System if you have a cardiac pacemaker, implanted defibrillators or any other implanted metallic or electronic device.
- Do not use this System if you have undiagnosed chronic pain.
- If you are under the care of a physician, consult with your physician before using this System.
- Do not use during pregnancy.
- Do not place the electrodes on or close to your heart.
- Do not place the electrodes around or close to your neck. Do not apply stimulation over the neck. Severe spasm of the muscles may occur and the contractions may be strong enough to close the airway or cause difficulty in breathing. Stimulation over the neck could also have adverse effect hearing or blood pressure.
- Do not apply stimulation across the chest because the introduction of electrical current into the chest may cause rhythm disturbances to the heart.
- Do not place the electrodes on or around your head. The effects of stimulation of the brain are unknown.
- Do not use this System while sleeping.
- Do not use if you feel numbness.
- Do not use this System in or close to water.
- Use the electrodes only on normal, healthy, clean and dry skin. Do not use the electrodes on open wounds or rashes, or over swollen, red, infected or inflamed skin.
- If you have ever had back surgery, consult your physician before using this System.
- If you have had medical or physical treatment for your muscle pain, consult with your treatment provider before using this System. You should contact your physician prior to using the System following recent surgical procedures. Stimulation may disrupt the healing process.

CAUTION: DISCONTINUE USE AND CONSULT YOUR PHYSICIAN IF ANY OF THE FOLLOWING CONDITIONS APPLY TO YOU.

- If you have suspected or diagnosed heart problems.
- If you have suspected or diagnosed epilepsy.
- If you have a tendency to bleed internally following an injury.

3

- If areas of skin lack normal sensations, such as skin that tingles or is numb.
- During menstruation.
- The long-term effects of this System are not known.

CAUTION:

- The System is intended for individual person use for the temporary relief of lower back pain.
- The System is not effective for pain associated with Central Pain Syndromes, such as headaches.
- The System is for pain caused by muscle soreness, and should be placed only around muscles where pain originates on the lower back pain area.
- The pain may indicate that you have some other health problem. You should know the reason and source of your pain before using this System. Do not solely rely on the treatment of this System for pain.
- Some people may feel skin irritation or experience a very sensitive feeling in the skin due to electrical stimulation. If this occurs, stop using your System and consult your physician.
- Some people may feel skin irritation from the adhesive on the self-adhesive electrodes. If this occurs, stop using your System.
- Minor redness at stimulation placement is a normal skin reaction. It is not considered as skin irritation, and it will normally disappear within 30 minutes after the electrodes are removed. If the redness does not disappear after 30 minutes from the removal of electrodes, do not use the stimulator again until after the excessive redness has disappeared.
- Turn off the stimulator if the stimulation feels unpleasant or does not provide pain relief.
- Keep your System out of the reach of children.
- Do not use this System when driving, operating machinery or when swimming.
- The effectiveness of the System depends greatly on a person's individual physical condition. It may not always be effective for every user.
- Clean any adhesive residue left on the skin with soap and water.

Do not use alcohol or solvent based cleaning products on your skin.

- If skin under one of more electrodes feels irritated after using the stimulator for a long period of time, use the stimulator for a shorter period of time.
- Use your stimulator only with the electrodes, lead wire and accessories recommended by the manufacturer.
- Before removing the electrodes, be sure to turn OFF both power knobs to avoid unpleasant stimulation.

Adverse Reactions

- Skin irritation and burns under the electrodes have been reported by some people who have applied electronic stimulators to their skin.

SAVE THESE INSTRUCTIONS

Chapter 3: PACKAGE CONTENTS

Each ZZAEV8200TC pain relieve device comes complete with standard accessories and the standard labels as given below:

	DESCRIPTION	Q'TY
1.	40 X 40 mm Adhesive Electrodes	4 pieces
2.	Electrodes Leads	2 pieces
3.	9 V Battery, type 6F22	1 piece
4.	Instruction Manual	1 piece
5.	Carrying Case	1 piece

Chapter 4: PARTS OF STIMULATOR

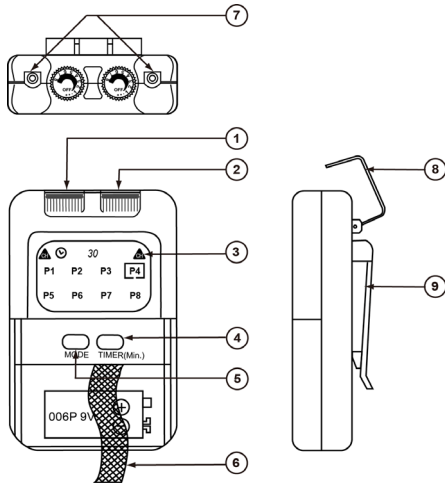

1. On/Off and Amplitude Control
2. On/Off and Amplitude Control
3. LCD
4. Timer Control
5. Mode Selector
6. Battery Strip
7. Lead Connector
8. Flip Top Cover
9. Belt Clip

Chapter 5: HOW YOUR TENS WORKS

The main function of pain relief comes from the continuous stimulation pulse generated from the dual channel stimulator. We can not ensure that the pain relief is 100% effective for everyone.

Chapter 6: CONDITIONS THAT MAY AFFECT YOUR PAIN RELIEF SYSTEM

Since the stimulator is a battery-operated electronic system, its output performance and safety may be affected greatly in extreme humidity. Therefore, it is very important to keep the stimulator dry to ensure the safety and performance of the stimulator.

Chapter 7 : QUICK OPERATION GUIDE

Your may use the following simple operation steps to operate this System.

- Step 1. Insert the 9-volt battery into your stimulator
- Step 2. Apply electrode electrodes to the skin
- Step 3. Connect the lead wire
- Step 4. Turn the stimulator "ON", adjusting the amplitude adjustment knobs to the desired stimulation strength
- Step 5. Select the therapy mode
- Step 6. Select the stimulation time
- Step 7. Enjoy the benefits
- Step 8. Turn off stimulator
- Step 9. Locking and unlocking the stimulator settings
- Step 10. Viewing the therapy timer

For the details of operation, please see the following operating instructions.

Chapter 8: ATTACHMENT OF ELECTRODE

LEAD WIRES

The wires provided with the system insert into the jack sockets located on top of the device. Holding the insulated portion of the connector, push the plug end of the wire into one of the jacks (see drawing); one or two sets of wires may be used.

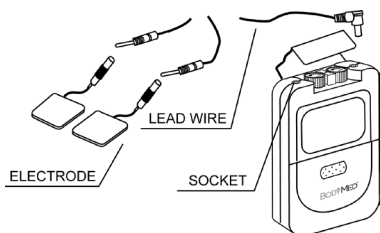

After connecting the wires to the stimulator, attach each wire to an electrode. Use care when you plug and unplug the wires. Jerking the wire instead of holding the insulated connector body may cause wire breakage.

CAUTION

Do not insert the plug of the patient lead wire into any AC power supply socket.

Chapter 9: LEAD WIRE MAINTENANCE

Clean the wires by wiping with a damp cloth. Coating them lightly with talcum powder will reduce tangling and prolong life.

Chapter 10: ELECTRODE OPTIONS

The electrodes are disposable and should be routinely replaced when they start to lose their adhesive nature. If you are unsure of your electrode adhesive properties, order replacement electrodes. Replacement electrodes should be re-ordered through or on the advice of your physician to ensure proper quality. Follow application procedures outlined in electrode packing, to maintain optimal stimulation and to prevent skin irritation.

Chapter 11: ELECTRODE PLACEMENT

The placement of electrodes can be one of the most important paragraphs in achieving success with TENS therapy. It is important that the physician experiments to determine optimum electrode placement.

Chapter 12: TIPS FOR SKIN CARE

To avoid skin irritation, especially if you have sensitive skin, follow these suggestions:

1. Wash the area of skin where you will be placing the electrodes, using mild soap and water before applying electrodes, and after taking them off. Be sure to rinse soap off thoroughly and dry skin well.
2. Excess hair may be clipped with scissors; do not shave stimulation area.
3. Wipe the area with the skin preparation your physician has recommended. Let this dry. Apply electrodes as directed.
4. Many skin problems arise from the "pulling stress" from adhesive patches that are excessively stretched across the skin during application. To prevent this, apply electrodes from centre outward; avoid stretching over the skin.
5. To minimize "pulling stress", tape extra lengths of lead wires to the skin in a loop to prevent tugging on electrodes.
6. When removing electrodes, always remove by pulling in the

direction of hair growth.

7. It may be helpful to rub skin lotion on electrode placement area when not wearing electrodes.
8. Never apply electrodes over irritated or broken skin.

Chapter 13: APPLICATION OF RE-USABLE SELF ADHESIVE ELECTRODES



Figure 1



Figure 2



Figure 3



Figure 4



Figure 5

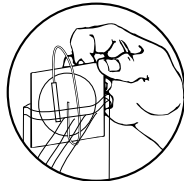

Figure 6



Figure 7



Figure 8

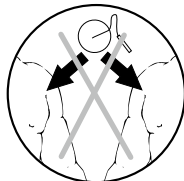

Figure 9

Application

1. Clean and dry the skin at the prescribed area thoroughly with soap and water prior to application of electrodes.
2. Insert the lead wire into the pin connector on the pre-wired electrodes.
3. Remove the electrodes from the protective liner and apply the electrodes firmly to the treatment site.

Removal

1. Lift at the edge of electrodes and peel; do not pull on the lead wires because it may damage the electrodes.
2. Place the electrodes on the liner and remove the lead wire by twisting and pulling at the same time.

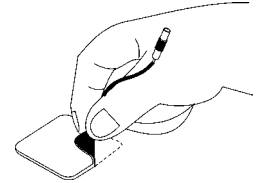

Care and Storage

1. Between uses, store the electrodes in the resealed bag in a cool dry place.
2. It may be helpful to improve repeated application by spreading a few drops of cold water over the adhesive and turn the surface up to air dry. Over saturation with water will reduce the adhesive properties.

Important

1. Do not apply to broken skin.
2. The electrodes should be discarded and re-ordered from your physician when they are no longer adhering.
3. The electrodes are intended for single patient use only.
4. If irritation occurs, discontinue use and consult your physician.
5. Read the instructions for use of self-adhesive electrodes before application.

Chapter 14: OPERATING INSTRUCTIONS

1. Slide-on Cover:

A slide-on panel cover covers the controls for selecting mode and adjusting settings. Your medical professional may wish to set these controls for you and request that you leave the cover in place.

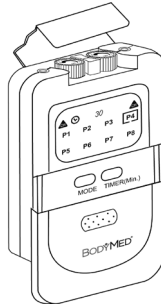

2. Power On/Off Switch and Intensity Controls:

If both controls are in the off-position, the device is switched off. By turning the controls clockwise, the appropriate channel is switched on and the indicator of power (CH1 or CH2) will reveal on the LCD.

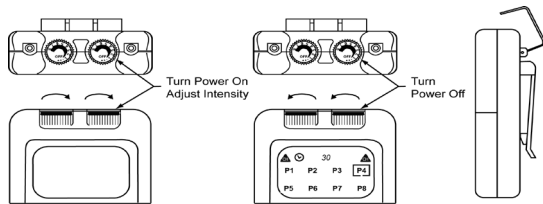

The current strength of the impulses transmitted to the electrodes increases further when the control is turned clockwise.

To reduce the current strength or switch the device off, turn the control counter clockwise to the required setting or off-position, respectively.

The controls are protected by a cap to avoid unintentional change of intensity.

3. Lead Connector

Connection of the electrodes is made with the two-lead connector (lead wires). The device must be switched off before connecting the lead wire. Both intensity controls must be at the Off position. Electrodes must be pressed firmly on the skin.

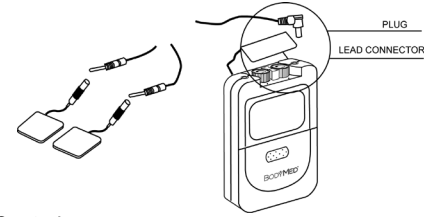

4. Mode Control

There are 8 programs of option from P1 to P8. Press this bottom to select a program desired.



5. Timer

The treatment time can be selected by pressing the "Timer" control. There are five settings available: 15, 30, 60 minutes and continue. Press the "Timer" control to select a.

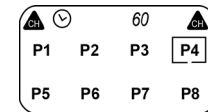

6. Low Battery Indicator

A low battery indicator will show up when the battery is low. Replace battery when the stimulation can not be felt.

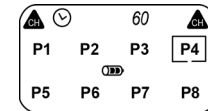

7. Check/Replace the Battery:

Over time, in order to ensure the functional safety of TENS, changing the battery is necessary.

1. Make sure that both intensity controls are switched to Off position.
2. Slide the battery compartment cover and open.
3. Remove the battery from the compartment.
4. Insert the battery into the compartment. Note the polarity indicated on the battery and in the compartment.
5. Replace the battery compartment cover and press to close.

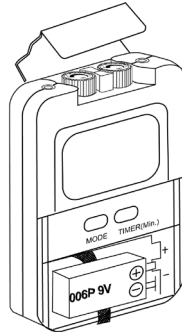

Chapter 15: BATTERY INFORMATION

PRECAUTIONS

1. Remove battery if equipment is not likely to be used for some time.
2. Please recycle the used battery in accordance with domestic regulation.
3. Do not throw the used battery into a fire.

If you use rechargeable batteries, please follow the instructions.

RECHARGEABLE BATTERIES(NOT INCLUDED)

Prior to the use of a new unit, the rechargeable battery should be charged according to the battery manufacturer's instructions. Before using the battery charger, read all instructions and cautionary markings on the battery and in this instruction manual.

After being stored for 60 days or more, the batteries may lose their charge. After long periods of storage, batteries should be charged prior to use.

BATTERY CHARGING

- (1) Plug the charger into any working 110 or 220/240v mains electrical outlet. The use of any attachment not supplied with the charger may result in the risk of fire, electric shock, or injury to persons.
- (2) Follow the battery manufacturer's instructions for charging time.
- (3) After the battery manufacturer's recommended charging time has been completed, unplug the charger and remove the battery.
- (4) Batteries should always be stored in a fully charged state.

To ensure optimum battery performance, follow these guidelines:

- (a) Although overcharging the batteries for up to 24 hours will not damage them, repeated overcharging may decrease useful battery life.
- (b) Always store batteries in their charged condition. After a battery has been discharged, recharge it as soon as possible. If the battery is stored more than 60 days, it may need to be recharged.
- (c) Do not short the terminals of the battery. This will cause the battery to get hot and can cause permanent damage. Avoid storing the may accidentally batteries in your pocket or purse where the terminals may accidentally come into contact with coins, keys or any metal objects.

(d) WARNINGS:

1. Do not attempt to charge any other types of batteries in your charger, other than rechargeable batteries made for your charger. Other types of batteries may leak or burst.
2. Do not incinerate the rechargeable battery as it may explode!

Chapter 16: MAINTENANCE, TRANSPORTATION AND STORAGE OF TENS DEVICE

1. Non-flammable cleaning solution is suitable for cleaning the device.
Note: Do not smoke or work with open lights (for example, candles, etc.) when working with flammable liquids.
2. Stains and spots can be removed with a cleaning agent.
3. Do not submerge the device in liquids or expose it to large amounts of water.
4. Return the device to the carrying box with sponge foam to ensure that the unit is well-protected before transportation.
5. If the device is not to be used for a long period of time, remove the batteries from the battery compartment (acid may leak from used batteries and damage the device). Put the device and accessories in carrying box and keep it in cool dry place.
6. The packed TENS device should be stored and transported under the temperature range of $-20^{\circ}\text{C} \sim +60^{\circ}\text{C}$, relative humidity 20% ~ 95%, atmosphere pressure 500 hPa ~ 1060 hPa.

Chapter 17: SAFETY-TECHNICAL CONTROLS

For safety reasons, review the following checklist before using your ZZAEV820OTC pain relief system

1. Check the device for external damage.
 - Deformation of the housing.
 - Damaged or defective output sockets.
2. Check the device for defective operating elements.
 - Legibility of inscriptions and labels.
 - Make sure the inscriptions and labels are not distorted.
3. Check the usability of accessories.
 - Patient cable undamaged.
 - Electrodes undamaged.
 - Battery is not corroded

Please consult your distributor if there are any problems with device and accessories.

Chapter 18: WHEN TO ORDER NEW ELECTRODES

The adhesive electrode electrodes are reusable. Electrodes should be replaced when they lose their adhesive quality, or you sense a change in stimulation sensation. To order new electrodes, see replacement Parts on page 17.

Chapter 19: WARRANTY

All ZZAEV820OTC TENS DEVICE models carry a warranty of one year from the date of delivery. The warranty applies to the stimulator only and covers both parts and labor relating thereto.

The warranty does not apply to damage resulting from failure to follow the operating instructions, accidents, abuse, alteration or disassembly by unauthorized personnel.

Chapter 20: REPLACEMENT PARTS

Contact your distributor to order replacement parts.

- Lead wires
- Electrodes
- Batteries

Chapter 21: CONFORMITY TO STANDARDS

The Stimulator is in compliance with:

- ANSI/AAMI ES 60601-1 – Safety of medical electrical equipment – General safety.
- IEC 60601-1-2: EMC test
- ANSI/AAMI NS 4 – Transcutaneous Electrical Nerve Stimulators

Chapter 22: TROUBLE SHOOTING GUIDE

If you have a problem using your ZZAEV8200TC Pain Relief System, review the following table to find a solution.

Problem	Solution
The stimulator will not turn on.	Check the battery – be sure it is firmly in place. Change the battery if necessary.
The stimulator turns on and then off quickly.	Replace the battery.
The stimulator is on, but there is no stimulation.	Check the lead wire for breakage. If broken, replace.
The display is frozen in some mode and the lock symbol appears.	You are in "Lock" function now. The following steps will reset the unit to normal function. 1. With unit off, press and hold down the TIME Button. 2. With the TIME button pressed, turn the unit on. 3. Press the UP arrow once to turn the "LOCK" symbol off. 4. Turn unit off. 5. Turn the unit on normally, it will back to normal function.
The stimulator has a new 9-volt battery, but will not turn on.	Please consult or return the device to your dealer.

Chapter 23: STIMULATOR TECHNICAL SPECIFICATIONS

Stimulator Technical Specifications

Power Source: 9 Volt battery.

Wave Form: Asymmetrical Bi-Phasic Square Pulse

Dimensions: 110 x 62 x 27mm.

Weight: Approx. 142 grams (battery included)

Program	Max.	Phase Duration	Rate	Function Mode
P1	80mA	260µs	15Hz	Constant
P2	80mA	260µs	100Hz	Burst
P3	80mA	260µs	120Hz	Constant
P4	80mA	260~150µs	2~100Hz	Modulated
P5	80mA	260µs	100Hz	Modulated
P6	80mA	260µs	80<->7 Hz	Modulated
P7	80mA	260µs	120Hz	Modulated
P8	80mA	P1~P7		Cycle

Timer: 15, 30, 60 minutes, and continuous mode selectable.